

Basic operation and functions

U10 series is single and dual output DC/DC converters provide from 6.6 watts up to 10watts of output power in an industry standard 1"x2" size package. The U10 series features 4:1 input voltage range, high efficiency, fixed switching frequency 300KHz, continuous short circuit protection, six-side continuous shield and 500VDC isolation.

Input (Vi+ , Vi-)

Input power Vin+ must be connected to Positive input voltage(Vi+) ; Input power Vin- must be connected to Negative voltage(Vi-).

Output (Vo+ , Vo-)

Output power Vout+ must be connected to Positive output voltage (Vo+) ; Output power Vout- must be connected to Negative output voltage (Vo-).

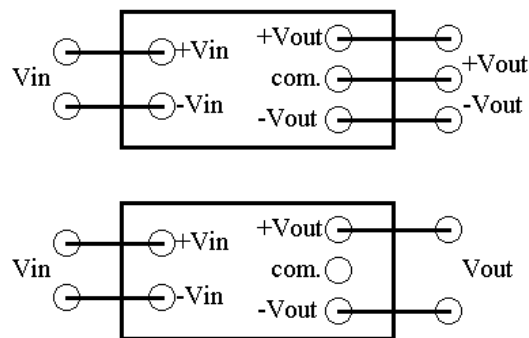

Protection Features

Input under voltage lockout(UVLO)

Input under voltage lockout(UVLO) is standard with the U10 unit. The unit will shut down when the input voltage drops below a threshold, and the unit will turn on when the input voltage goes to the upper threshold. The hysteresis voltage of the unit voltage protection is 0.4V(tpical), normally from the 8V to 7.6V range.

Output over current protection(OCP) and output short protection

The unit will auto recovery current limit when the over current or short circuit condition exists.

Once the OCP happens, the unit has auto recovery current limit and output voltage above 6V. The attempted restart will continue indefinitely until the over current or short circuit condition is removed.

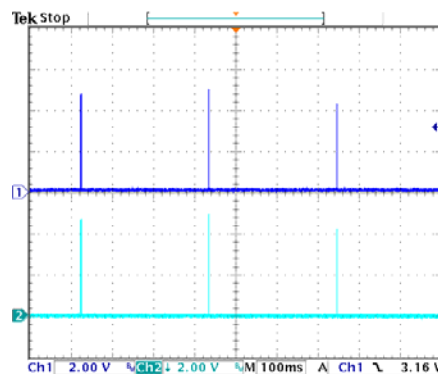

CH1:+Vout/OCP Ch2:-Vout/OCP

When output short happens, the output voltage drops below 0.2V.

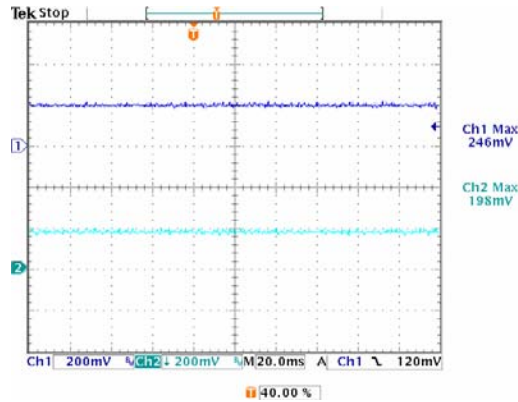

CH1:+Vout/short Ch2:-Vout/short

Characterization

General information

The U10 unit has many operational characterized aspects, including efficiency, start up , overshoot, output ripple & noise, hold time, dynamic response to load and input ripple current.

The following pages contain specific plots or waveforms associated with the unit. Additional comments for specific data are provided below. And all test function at 24Vinput.

Efficiency

Efficiency vs load current is given below. The ambient temperature is 25°C, airflow is 20LFM(0.1m/s), and the input voltage is 9V, 24V and 36V conditions.

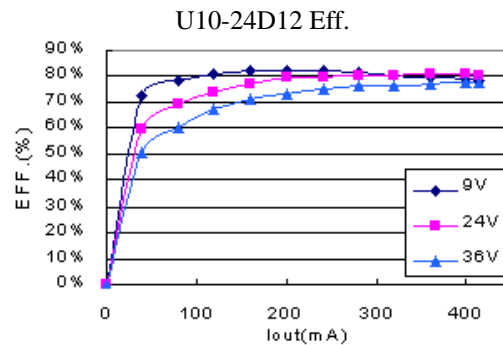

Start up

The input start-up from power supply.

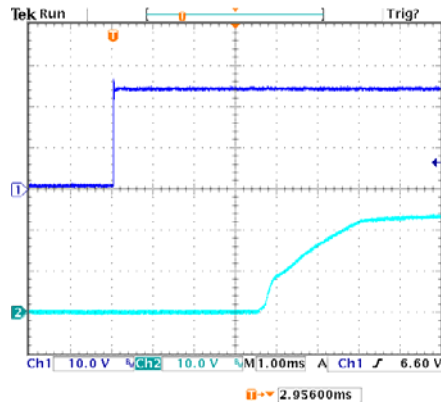

CH1:Vin=24V CH2:Vout=24V / FL
 Start up delay time:5.84ms

Overshoot and rise time

The input start-up from power supply.
 The output voltage waveform measured at minimum load and full load current.

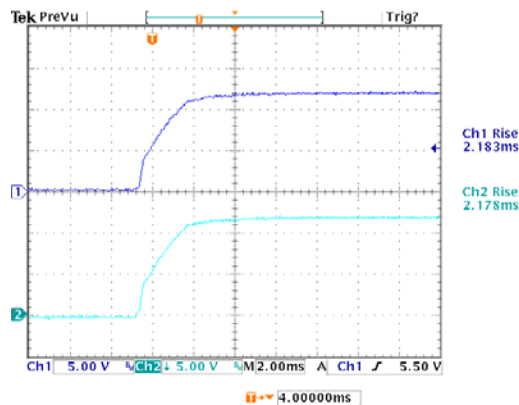

CH1:+Vout/FL Ch2:-Vout/FL
 Overshoot:zero %
 Rise time:2.183ms / 2.178ms

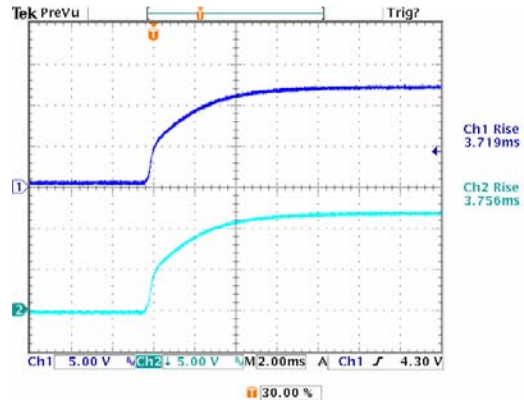

CH1:+Vout/NL Ch2:-Vout/NL
 Overshoot:zero %
 Rise time:3.719ms / 3.756ms

Output Ripple and Noise

The output voltage waveform measured at minimum load and full load current, with a 0.1uF ceramic capacitor across to close unit.

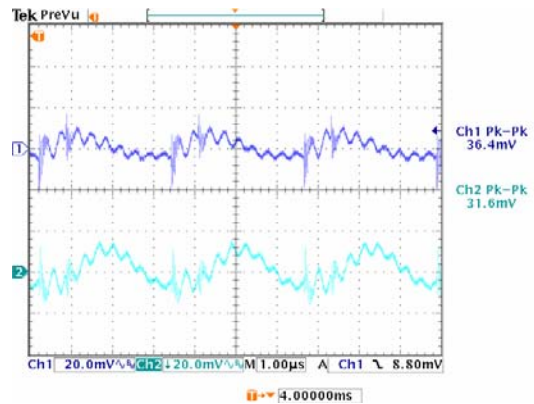

CH1:+Vout/FL Ch2:-Vout/FL
 Ripple:36.4mVp-p / 31.6mVp-p

Hold time

The hold time is measure from the power supply end or on/off pin is off to when Vout drop down to 90% output.

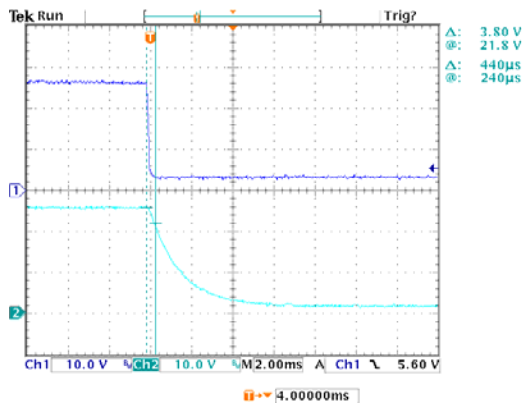

CH1:Vin Ch2:Vout/FL
 Hold time:440us

Dynamic response

Output voltage dynamic response at Vin=24V and different load condition. Output with a 0.1uF ceramic capacitor.

CH1:Vout Ch2:Iout, 0.1A/us
 Load change 25%-75%-25%

Input ripple current

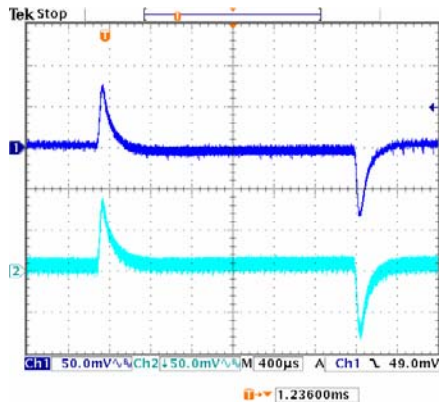
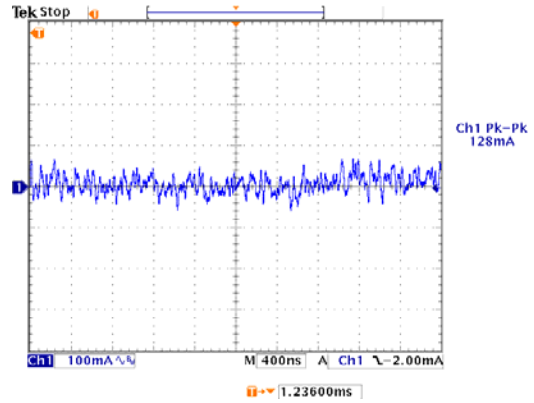

CH1:Vout Ch2:Iout, 0.1A/us
 Load change 50%-100%-50%

