



NON-ISOLATED DC-DC Converter

**S15 SIP / SMT SERIES
3.0-5.5V_{in}, 0.9-3.63V_{out}, 15A**

**APPLICATION NOTES
Ver 1.0**



S15-5S3.3T (Through-Hole) Converter

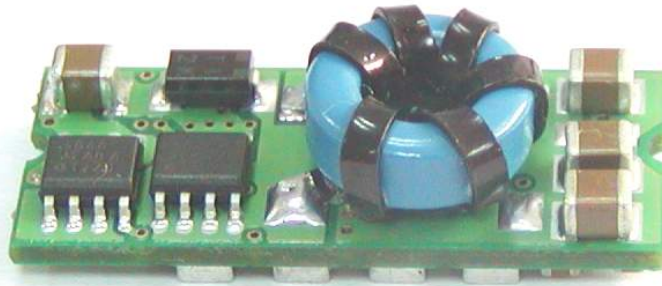

S15-5S3.3 SMT Version Converter

1. INTRODUCTION	3
2. MODELS	3
3. 15A SIP/SMT CONVERTER FEATURES	3
4. GENERAL DESCRIPTION	3
4.1 Electrical Description	3
4.2 Thermal Packaging and Physical Design.	4
5. MAIN FEATURES AND FUNCTIONS	4
5.1 Operating Temperature Range	4
5.2 Over-Temperature Protection (OTP)	4
5.3 Output Voltage Adjustment	4
5.4 Safe Operating Area (SOA)	4
5.5 Over Current Protection	4
5.6 Remote ON/OFF	4
5.7 UVLO (Under-Voltage Lockout)	5
6. SAFETY	5
6.1 Input Fusing and Safety Considerations.	5
7. APPLICATIONS	5
7.1 Layout Design Challenges.	5
7.2 Convection Requirements for Cooling	6
7.3 Thermal Considerations	6
7.4 Power De-Rating Curves	7
7.5 Input Capacitance at the Power Module	7
7.6 Test Set-Up	8
7.7 Remote Sense Compensation	8
7.8 S15-5S3.3 Output Voltage Adjustment.	8
7.9 Output Ripple and Noise Measurement	9
7.10 Output Capacitance	9
7.11 SMT Reflow Profile	9
8. MECHANICAL OUTLINE DIAGRAMS	10
8.1 SIP/SMT15 Mechanical Outline Diagrams	10
8.2 SMT Tape and Reel Dimensions	10

1. Introduction

This application note describes the features and functions of Intronics' S15-5S3.3 of Non Isolated DC-DC Converters. These are highly efficient, reliable and compact, high power density, single output DC/DC converters. These "Point of Load" modules serve the needs specifically of the fixed and mobile telecommunications and computing market, employing economical distributed Power Architectures.

The S15-5S3.3 provide precisely regulated output voltage range from 0.9V to 3.63Vdc over a wide range of input voltage ($V_i=3.0 - 5.5Vdc$) and can operate over an ambient temperature range of $-40C$ to $+85C$. Ultra-high efficiency operation is achieved through the use of synchronous rectification and drive control techniques. The modules are fully protected against short circuit and over-temperature conditions.

Intronics' world class automated manufacturing methods, together with an extensive testing and qualification program, ensure that all S15-5S3.3 converters are extremely reliable.

2. Models

The adjustable S15-5S3.3 series models are shown in table1 :

Model	Input Voltage	Output Voltage	Output Current
S15-5S3.3T	3.0 – 5.5VDC	0.9 – 3.63VDC	15A
S15-5S3.3	3.0 – 5.5VDC	0.9 – 3.63VDC	15A

Table 1 – 15A SIP/SMT Models

3. S15-5S3.3 Converter Features

- High efficiency topology, typically 94% at 3.3Vdc
- Industry standard footprint
- Wide ambient temperature range, $-40C$ to $+85C$
- Cost efficient open frame design
- Programmable output voltage via external resistor from 0.9 to 3.63Vdc
- No minimum load requirement (Stable at all loads)
- Remote ON/OFF
- Remote sense compensation
- Fixed switching frequency
- Continuous short-circuit protection and over current protection
- Over-temperature protection (OTP)
- Monotonic Startup with pre-bias at the output.
- UL/IEC/EN60950 Certified.

4. General Description

4.1 Electrical Description

A block diagram of the S15-5S3.3 converter is shown in Figure 1. Extremely high efficiency power conversion is achieved through the use of synchronous rectification and drive techniques. Essentially, the powerful S15-5S3.3 topology is based on a non-isolated synchronous buck converter. The control loop is optimized for unconditional stability, fast transient response and a very tight line and load regulation. In a typical pre-bias application the S15-5S3.3 converters do not draw any reverse current at start-up.

The output voltage can be adjusted from 0.9 to 3.63vdc , using the TRIM pin with an external resistor.

The converter can be shut down via a remote ON/OFF input that is referenced to ground. This input is compatible with popular logic devices; a 'negative' logic input is supplied as standard. Negative logic implies that the converter is enabled if the remote ON/OFF input is low (or floating), and disabled if it is high.

The converter is also protected against over-temperature conditions. If the converter is overloaded or the ambient temperature gets too high, the converter will shut down to protect the unit.

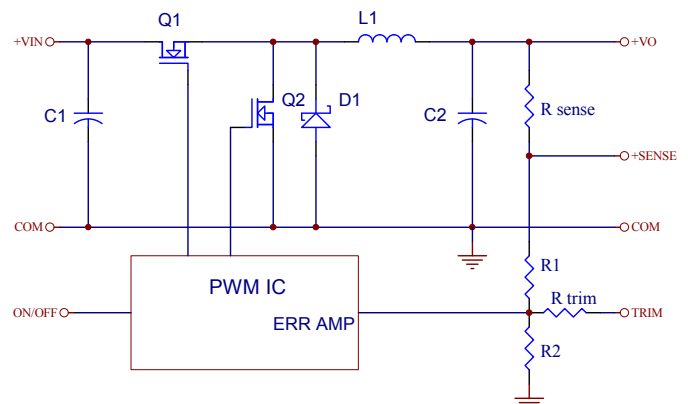

Figure 1. Electrical Block Diagram

4.2 Thermal Packaging and Physical Design.

The S15-5S3.3 uses a multi-layer FR4 PCB construction. All surface mount power components are placed on one side of the PCB, and all low-power control components are placed on the other side. Thus, the Heat dissipation of the power components is optimized, ensuring that control components are not thermally stressed.

The converter is an open-frame product and has no case or case pin. The open-frame design has several advantages over encapsulated closed devices. Among these advantages are:

- **Efficient Thermal Management:** the heat is removed from the heat generating components without heating more sensitive, small signal control components.
- **Environmental:** Lead free open-frame converters are more easily re-cycled.
- **Cost Efficient:** No encapsulation. Cost efficient open-frame construction.
- **Reliable:** Efficient cooling provided by open frame construction offers high reliability and easy diagnostics.

5. Main Features and Functions

5.1 Operating Temperature Range

Intronics' S15-5S3.3 converters highly efficient converter design has resulted in its ability to operate over a wide ambient temperature environment (-40C to 85C). Due consideration must be given to the de-rating curves when ascertaining maximum power that can be drawn from the converter. The maximum power drawn is influenced by a number of factors, such as:

- Input voltage range.
- Output load current.
- Air velocity (forced or natural convection).
- Mounting orientation of converter PCB with respect to the Airflow.
- Motherboard PCB design, especially ground and power planes. These can be effective heatsinks for the converter.

5.2 Over-Temperature Protection (OTP)

The S15-5S3.3 converters are equipped with non-latching over-temperature protection. A temperature sensor monitors the temperature of the hot spot (typically, top switch). If the temperature exceeds a threshold of 120°C (typical) the converter will shut down, disabling the output. When the temperature has decreased the converter will automatically restart.

The over-temperature condition can be induced by a variety of reasons such as external overload condition or a system fan failure.

5.3 Output Voltage Adjustment

Section 7.8 describes in detail as to how to trim the output voltage with respect to its set point. The output voltage on all models is trimmable in the range 0.9 – 3.63Vdc.

5.4 Safe Operating Area (SOA)

Figure 2 provides a graphical representation of the Safe Operating Area (SOA) of the converter. This representation assumes ambient operating conditions such as airflow are met as per thermal guidelines provided in Sections 7.2 and 7.3.

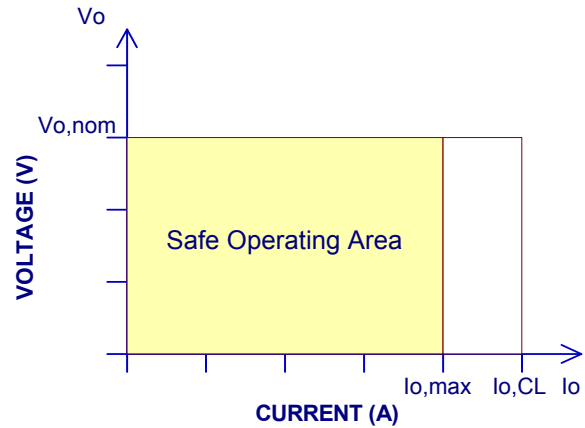

Figure 2. Maximum Output Current Safe Operating Area

5.5 Over Current Protection

All different voltage models have a full continuous short-circuit protection. The unit will auto recover once the short circuit is removed. To provide protection in a fault condition, the unit is equipped with internal over-current protection. The unit operates normally once the fault condition is removed. The power module will supply up to 140% of rated current. In the event of an over current converter will go into a hiccup mode protection.

5.6 Remote ON/OFF

The remote ON/OFF input feature of the converter allows external circuitry to turn the converter ON or OFF. Active-low remote ON/OFF is available as standard.

The S15-5S3.3 converters are turned on if the remote ON/OFF pin is low, or left open or floating. Pulling the pin high will turn the converter 'Off'. The signal level of the remote on/off input is defined with respect to ground. The unit is guaranteed OFF over the full temperature range if this voltage level exceeds 2.8Vdc.

The remote ON/OFF input can be driven as described in Figure 3.

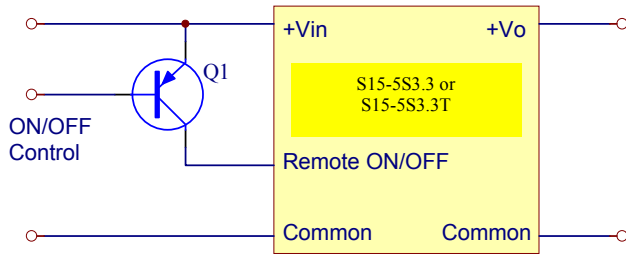
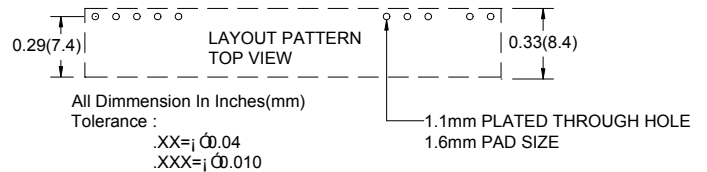

Figure 3 . Remote ON/OFF Input Drive Circuit

Low resistance and low inductance PCB layout traces are the norm and should be used where possible. Due consideration must also be given to proper low impedance tracks between power module, input and output grounds.



VIEW IS FROM TOP SIDE
Figure 4A. Recommended SIP Footprint

Recommended Pad Layout

Dimensions are in millimetres and(inches)

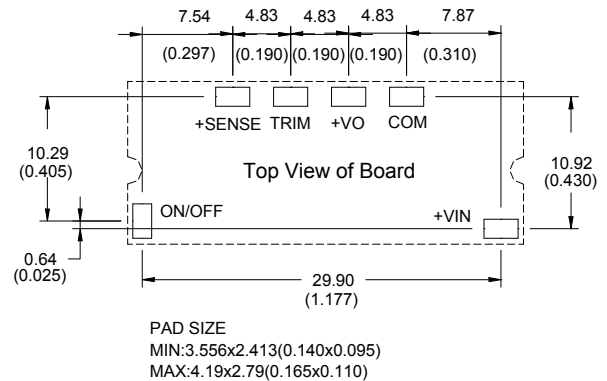

Figure 4B. Recommended SMT Footprint

5.7 UVLO (Under-Voltage Lockout)

The voltage on the Vcc pin determines the start of the operation of the Converter. When the input Vcc rises and exceeds about 2.8V the converter initiates a soft start. The UVLO function in the converter has a Hysteresis (about 100mV) built in to provide noise immunity at start-up.

6. Safety

6.1 Input Fusing and Safety Considerations.

Agency Approvals: The power Supply shall be submitted to and receive formal approval from the following test agencies.

- 1.The power supply shall be approved by a nationally recognized testing laboratory to UL/CSA 60950 3rd Edition (North America) and EN60950 (International)
2. CB Certificate from an internationally recognized test house in accordance with EN 60950.

The S15-5S3.3 converters do not have an internal fuse. However, to achieve maximum safety and system protection, always use an input line fuse. The safety agencies require a time-delay fuse with a maximum rating of 20A.

7. Applications

7.1 Layout Design Challenges.

In optimizing thermal design the PCB is utilized as a heatsink. Also some heat is transferred from the SIP module to the main board through connecting pins. The system designer or the end user must ensure that other components and metal in the vicinity of the S15-5S3.3 meet the spacing requirements to which the system is approved.

7.2 Convection Requirements for Cooling

To predict the approximate cooling needed for the module, refer to the Power De-rating curves in Figures 9 and 10. These de-rating curves are approximations of the ambient temperatures and airflows required to keep the power module temperature below its maximum rating. Once the module is assembled in the actual system, the module's temperature should be checked as shown in Figure 5 to ensure it does not exceed 110°C.

Proper cooling can be verified by measuring the power module's temperature at Q1-pin 6 and Q2-pin 6 as shown in Figure 6A,6B.

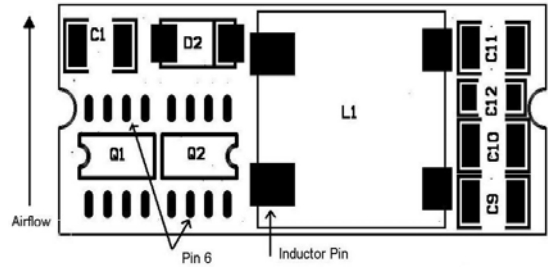

Figure 6B. Temperature Measurement Location for SMT

7.3 Thermal Considerations

The power module operates in a variety of thermal environments; however, sufficient cooling should be provided to help ensure reliable operation of the unit. Heat is removed by conduction, convection, and radiation to the surrounding environment. The thermal data presented is based on measurements taken in a set-up as shown in Figure 5. Figures 7, 8 represent the test data.

Note that the airflow is parallel to the long axis of the module as shown in Figure 6A for the SIP15.

The temperature at either location should not exceed 110 °C. The output power of the module should not exceed the rated power for the module (VO, set x IO, max).

The SMT15 thermal data presented is based on measurements taken in a wind tunnel. The test setup shown in Figure 5 and EUT need to solder on 33mm x 40.38mm(1.300" x 1.59") test pcb. Note that airflow is parallel to the long axis of the module as shown in Fig 6B

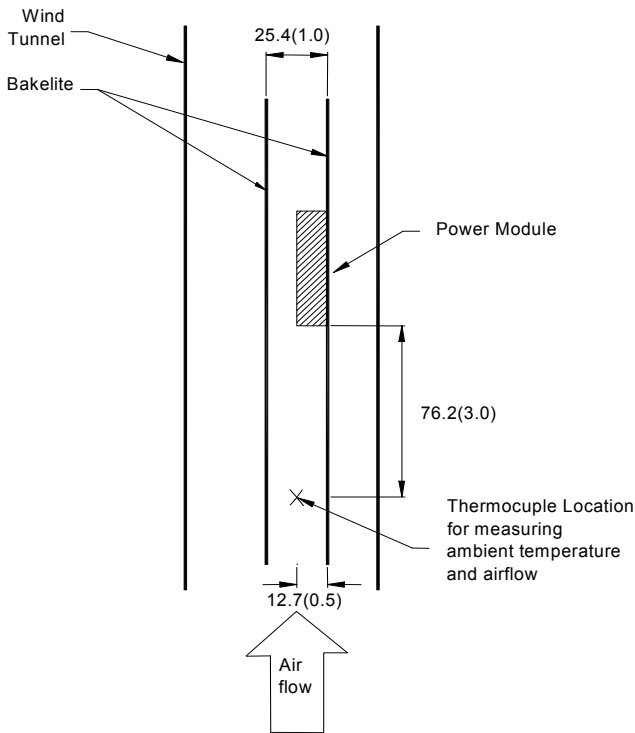

Note : Dimensions are in millimeters and (inches)

Figure 5. Thermal Test Setup

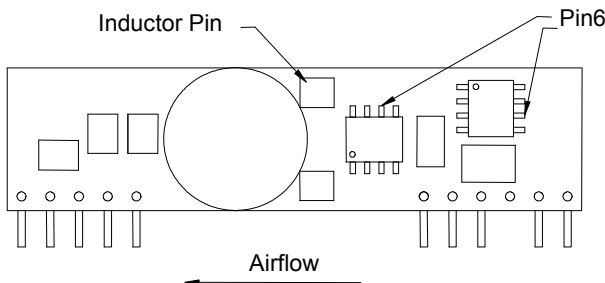

Figure 6A. Temperature Measurement Location for SIP

7.4 Power De-Rating Curves

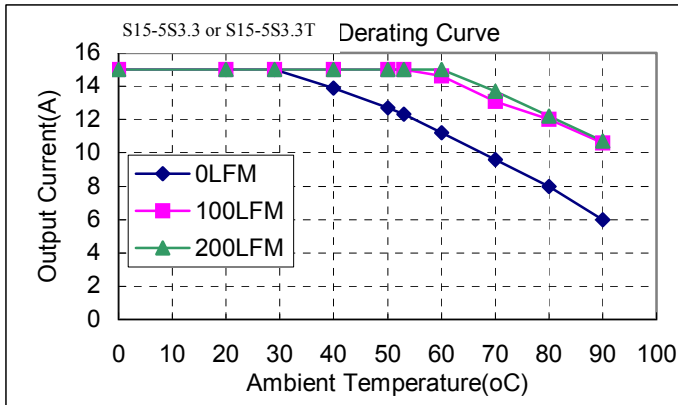

Figure 7. Typical Power De-rating for 5.0V IN(SIP15)

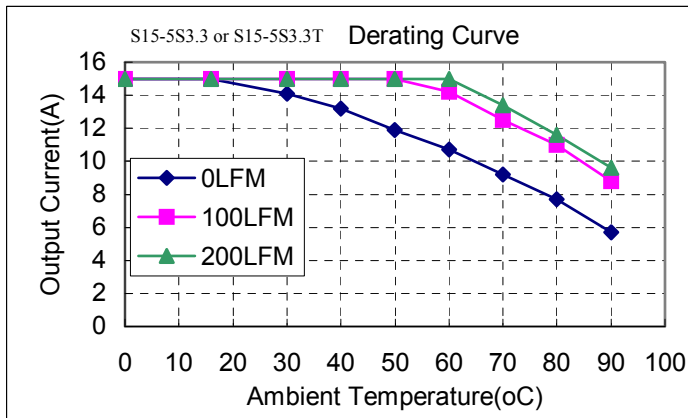

Figure 8. Typical Power De-rating for 5.0V IN (S15-5S3.3)

7.5 Input Capacitance at the Power Module

The SIP/SMT converters must be connected to a low AC source impedance. To avoid problems with loop stability source inductance should be low. Also, the input capacitors should be placed close to the converter input pins to de-couple distribution inductance. However, the external input capacitors are chosen for suitable ripple handling capability. Low ESR polymers are a good choice. They have high capacitance, high ripple rating and low ESR (typical <math><20\text{m}\Omega</math>). Electrolytic capacitors should be avoided. Circuit as shown in Figure 9 represents typical measurement methods for ripple current. Input reflected-ripple current is measured with a simulated source Inductance of 1uH. Current is measured at the input of the module.

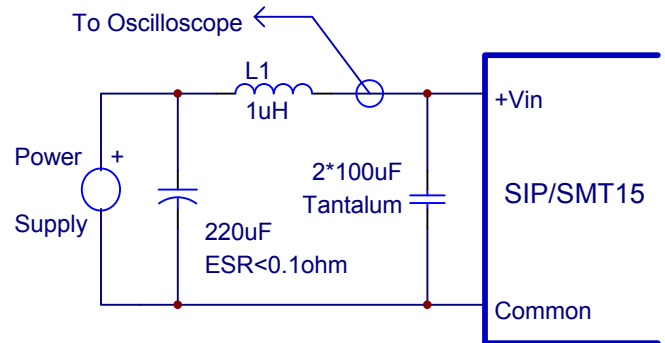

Figure 9. Input Reflected-Ripple Test Setup

7.6 Test Set-Up

The basic test set-up to measure parameters such as efficiency and load regulation is shown in Figure 10. Things to note are that this converter is non-isolated, as such the input and output share a common ground. These grounds should be connected together via low impedance ground plane in the application circuit. When testing a converter on a bench set-up, ensure that -Vin and -Vo are connected together via a low impedance short to ensure proper efficiency and load regulation measurements are being made. When testing the Intronics' S15-5S3.3 under any transient conditions please ensure that the transient response of the source is sufficient to power the equipment under test. We can calculate the

- Efficiency
- Load regulation and line regulation.

The value of efficiency is defined as :

$$\eta = \frac{V_o \times I_o}{V_{in} \times I_{in}} \times 100\%$$

Where: Vo is output voltage ,
 Io is output current,
 Vin is input voltage,
 Iin is input current.

The value of load regulation is defined as :

$$Load.reg = \frac{V_{FL} - V_{NL}}{V_{NL}} \times 100\%$$

Where: V_{FL} is the output voltage at full load
 V_{NL} is the output voltage at no load

The value of line regulation is defined as:

$$Line.reg = \frac{V_{HL} - V_{LL}}{V_{LL}} \times 100\%$$

Where: V_{HL} is the output voltage of maximum input voltage at full load.
 V_{LL} is the output voltage of minimum input voltage at full load.

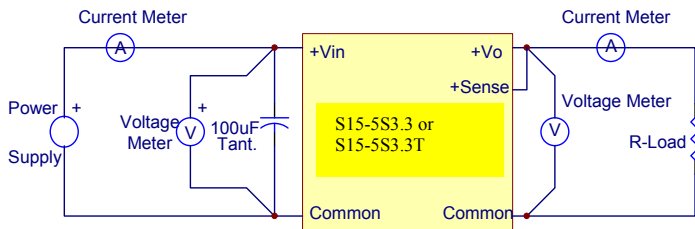

Figure 10. S15-5S3.3 Test Setup

7.7 Remote Sense Compensation

Remote Sense regulates the output voltage at the point of load. It minimizes the effects of distribution losses such as drops across the connecting pin and PCB tracks (see Figure 11). Please note however, the maximum drop from the output pin to the point of load should not exceed 500mV for remote compensation to work.

The amount of power delivered by the module is defined as the output voltage multiplied by the output current (VO x IO).

When using TRIM UP, the output voltage of the module will increase which, if the same output current is maintained, increases the power output by the module. Make sure that the maximum output power of the module remains at or below the maximum rated power.

When the Remote Sense feature is not being used, leave sense pin disconnected.

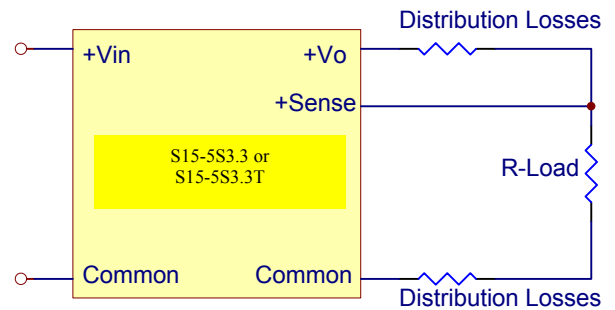

Figure 11. Circuit Configuration for Remote Sense Operation

7.8 S15-5S3.3 Output Voltage Adjustment.

The output Voltage of the S15-5S3.3 can be adjusted in the range 0.9V to 3.63V by connecting a single resistor on the motherboard (shown as Rtrim) in Figure 12. When Trim resistor is not connected the output voltage defaults to 0.75V

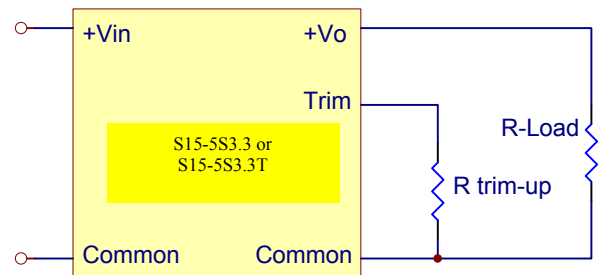

Figure 12. Trim-up Voltage Setup

The value of Rtrim-up defined as:

$$R_{trim} = \left(\frac{21070}{V_o - 0.75} - 5110 \right) \text{ k}\Omega$$

Where: Rtrim-up is the external resistor in KΩ,
 Vo is the desired output voltage

To give an example of the above calculation, to set a voltage of 3.3Vdc, Rtrim is given by:

$$R_{trim} = \left(\frac{21070}{3.3 - 0.75} - 5110 \right)$$

$$R_{trim} = 3.15 \text{ k}\Omega$$

For various output values various resistors are calculated and provided in Table 2 for convenience.

Vo,set (V)	Rtrim (KΩ)
0.90	135.36
1.00	79.17

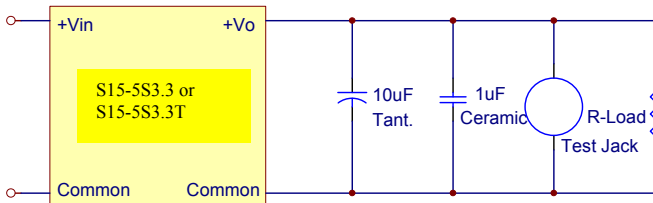

1.20	41.71
1.50	22.98
1.80	14.96
2.00	11.75
2.50	6.93
3.30	3.15
3.63	2.20

Table 2 – Trim Resistor Values

7.9 Output Ripple and Noise Measurement

The test set-up for noise and ripple measurements is shown in Figure 13. a 50Ω. coaxial cable with a 50Ω termination was used to prevent impedance mismatch reflections disturbing the noise readings at higher frequencies.

Figure 13. Output Voltage Ripple and Noise Measurement Set-Up

7.10 Output Capacitance

Intronics' S15-5S3.3 converters provide unconditional stability with or without external capacitors. For good transient response low ESR output capacitors should be located close to the point of load. For high current applications point has already been made in layout considerations for low resistance and low inductance tracks.

Output capacitors with its associated ESR values have an impact on loop stability and bandwidth. Intronics' converters are designed to work with load capacitance up-to 10,000uF. It is recommended that any additional capacitance, typically 1,000uF and low ESR (<20mΩ), be connected close to the point of load and outside the remote compensation point.

7.11 SMT Reflow Profile

An example of the SMT reflow profile is given in Figure 14.

Equipment used: SMD HOT AIR REFLOW HD-350SAR
 Alloy: AMQ-M293TA or NC-SMQ92 IND-82088 SN63

EMBED Excel.Chart.8 \s



Figure 14 – SMT Reflow Profile



8. Mechanical Outline Diagrams

8.1 S15-5S3.3 or S15-5S3.3T Mechanical Outline Diagrams

Dimensions are in millimeters and (inches)
 Tolerance : x.xx ±0.02 in.(0.5mm) , x.xxx ±0.010 in. (0.25 mm) unless otherwise noted

□

□

Figure 15. S15-5S3.3T Mechanical Outline Diagram

BOTTOM VIEW OF BOARD

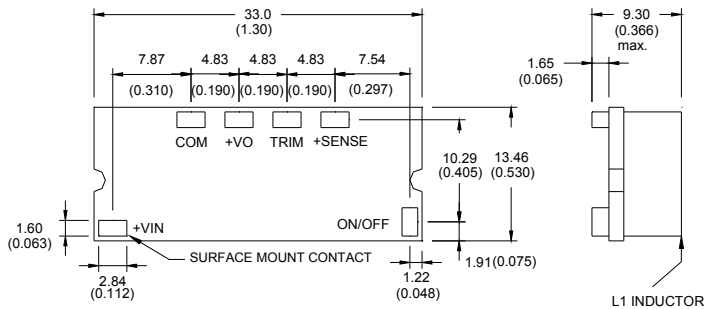

Dimensions are in millimeters(Inches)

Tolerances :X.Xj Ø.5mm(0.02in),X.XXj Ø.25mm(0.010in),unless otherwise noted.

Figure 16. S15-5S3.3 Mechanical Outline Diagram

8.2 SMT Tape and Reel Dimensions

The Tape Reel dimensions for the SMT module is shown in Figure 17.

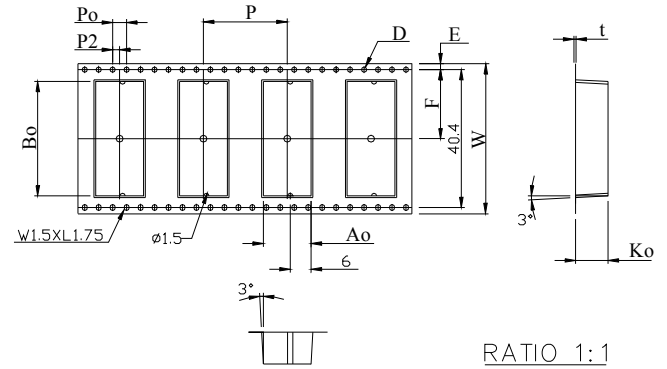

ITEM	SPEC
W	44.00 ^{+0.30} _{-0.30}
Ao	13.70 ^{+0.10} _{-0.10}
Bo	33.50 ^{+0.10} _{-0.10}
Ko	9.30 ^{+0.10} _{-0.10}
P	24.00 ^{+0.10} _{-0.10}
F	20.20 ^{+0.10} _{-0.10}
E	1.75 ^{+0.10} _{-0.10}
D	1.50 ^{+0.10} _{-0.05}
D1	2.00 ^{+0.25} _{-0.05}
Po	4.00 ^{+0.10} _{-0.10}
P2	2.00 ^{+0.10} _{-0.10}
t	0.40 ^{+0.05} _{-0.05}

Figure 17 – SMT Tape and Reel Dimensions