

MODEL 757N, 757P

## FEATURES

- 6 Decade Operation — 1nA to 1mA
- 1/2% Log Conformity — 10nA to 100 $\mu$ A
- Symmetrical FET Inputs
- Voltage or Current Operation
- Temperature Compensated

## APPLICATIONS

- Absorbance Measurements
- Log Ratios of Voltages or Currents
- Data Compression
- Transducer Linearization



## GENERAL DESCRIPTION

Model 757 is a complete, temperature compensated, dc-coupled log ratio amplifier. It is comprised of two input channels for processing signals spanning up to 6 decades in dynamic range (1nA to 1mA). By virtue of its symmetrical FET input stages, the 757 can accommodate this 6 decade signal range at either channel. Log conformity is maintained to within 1/2% over 4 decades of input (10nA to 100 $\mu$ A) and to within 1% over the full input range. Unlike other log ratio designs, model 757 does not restrict the relative magnitude of the two signal inputs to achieve rated performance. Either input can be operated within the specified range regardless of the signal level at the other channel.

The model 757 log-ratio amplifier design makes available both input amplifier summing junctions. As a result, it can directly interface with photo diodes operating in the short-circuit current mode without the need of additional input circuitry.

The excellent performance of model 757 can be further improved by means of external scale factor and output offset adjustments. A significant feature of model 757 not found on competing devices is that, when the offset adjustment is used to establish a fixed bias at the output, the output offset level does not vary as a function of input signal magnitude. On other designs, the sensitivity of output offset to input levels results in output effects resembling log conformity errors.

Model 757 can operate with either current or voltage inputs. Its excellent performance makes it ideally suited for log ratio applications such as blood analysis, chromatography, chemical analysis of liquids and absorbance measurements.

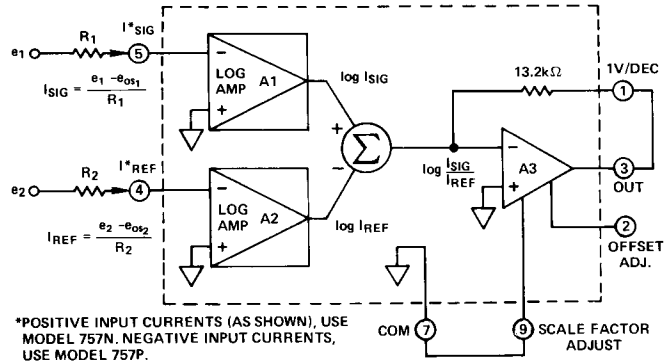

Figure 1. Functional Block Diagram of Model 757

## CURRENT LOG RATIO

Current log ratio is accomplished by model 757 when two currents,  $I_{SIG}$  and  $I_{REF}$ , are applied directly to the input terminals (see Figure 1). The two log amps process these signals providing voltages which are proportional to the log of their respective inputs. These voltages are then subtracted and applied to an output amplifier. The scale factor, when connected as shown, is 1V/dec. However, higher scale factors may be achieved by connecting external scale factor adjusting resistors. (See section on optional adjustments and trims.)

## VOLTAGE LOG RATIO

The principle of operation for voltage log ratio is identical to that of current log ratio after the voltage signal has been converted to a current. To accomplish this conversion, an external

(continued on page 3)

# SPECIFICATIONS

(typical @ +25°C and  $V_S = \pm 15V$  dc unless otherwise noted)

<b>MODEL</b>	757N/P	
<b>TRANSFER FUNCTION<sup>1</sup></b>		
Current Mode	$e_o = -K \log_{10} \frac{I_{SIG}}{I_{REF}}$	
Voltage Mode	$e_o = -K \log_{10} \left[ \frac{(e_1 - e_{os_1})}{(e_2 - e_{os_2})} \times \frac{R_2}{R_1} \right]$	
<b>ACCURACY</b>		
Log Conformity <sup>2</sup>		
$I_{SIG}, I_{REF} = 10nA$ to $100\mu A$	±0.5%, max	
$I_{SIG}, I_{REF} = 1nA$ to $1mA$	±1%, max	
Scale Factor (1V/Dec)	(+0, -2%) max	
vs. Temperature (0 to +70°C)	±0.04%/°C max	

<b>INPUT SPECIFICATIONS – Both Input Channels</b>		
<b>Current</b>		
<b>Signal Range, Rated Performance</b>		
Model 757N	+1nA to +1mA min	
Model 757P	-1nA to -1mA min	
Max Safe	±10mA max	
Bias Current, @ +25°C	(0, +) 10pA max	
vs. Temperature (0 to +70°C)	x2/+10°C	
Offset Voltage, @ +25°C	±1mV max	
vs. Temperature (0 to +70°C)		
$I_{SIG}$ Channel	±25μV/°C max	
$I_{REF}$ Channel	±25μV/°C max	
vs. Supply Voltage	±5μV/%	

<b>FREQUENCY RESPONSE, Sinewave</b>		
<b>Small Signal Response (-3dB)</b>		
<b>Signal Channel</b>		
$I_{SIG} = 1nA$	250Hz	
$I_{SIG} = 1\mu A$	25kHz	
$I_{SIG} = 100\mu A$	40kHz	
<b>Reference Channel</b>		
$I_{REF} = 1nA$	100Hz	
$I_{REF} = 1\mu A$	25kHz	
$I_{REF} = 100\mu A$	40kHz	

<b>RISE TIME</b>	<b>Signal Channel</b>	<b>Reference Channel</b>
<b>Increasing Input Current</b>	$(I_{REF} = 10\mu A)$	$(I_{SIG} = 10\mu A)$
1nA to 10nA	250μs	80μs
10nA to 100nA	50μs	40μs
100nA to 1μA	30μs	30μs
1μA to 100μA	25μs	25μs
<b>Decreasing Input Current</b>		
100μA to 1μA	25μs	25μs
1μA to 100nA	30μs	30μs
100nA to 10nA	100μs	40μs
10nA to 1nA	600μs	70μs

<b>INPUT NOISE</b>		
Voltage (10Hz to 10kHz)	3μV rms	
Current (10Hz to 10kHz)	0.1pA rms	

<b>OUTPUT SPECIFICATIONS</b>		
<b>Rated Output</b>		
Voltage	±10V min	
Current	±5mA min	
Resistance	0.1Ω	
Offset Voltage <sup>3</sup> (K = 1V/Decade)	±15mV max	
vs. Temperature (0 to +70°C)	±0.3mV/°C	
vs. Supply	±5μV/V	

<b>POWER SUPPLY<sup>4</sup></b>		
Rated Performance	±15V dc	
Operating	±(12 to 18)V dc	
Current, Quiescent	±8mA	

<b>TEMPERATURE RANGE</b>		
Rated Performance	0 to +70°C	
Operating	-25°C to +85°C	
Storage	-55°C to +125°C	

<b>MECHANICAL</b>		
Case Size	1.5" x 1.5" x 0.4"	
Weight	21 grams	

<sup>1</sup> For model 757N, K = +1V/Decade and input currents must be positive. For model 757P, K = -1V/Decade and input currents must be negative. (Input currents are defined as positive when flowing into the input terminals, 4 and 5. Refer to TRANSFER CURVES.)  
<sup>2</sup> The log conformity error is referred to input (RTI). 1% error RTI is equivalent to 4.3mV of error at the output for K = 1V/Dec.  
<sup>3</sup> Externally adjustable to zero.  
<sup>4</sup> Recommended power supply: Analog Devices model 904, ±15V @ 50mA.

Specifications subject to change without notice.

## OUTLINE DIMENSIONS

Dimensions shown in inches and (mm).

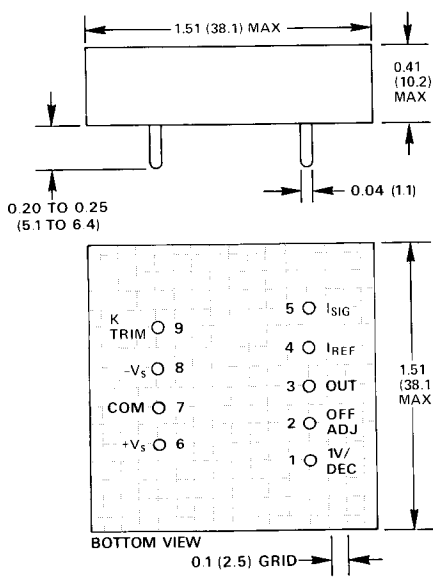

## TRANSFER CURVES

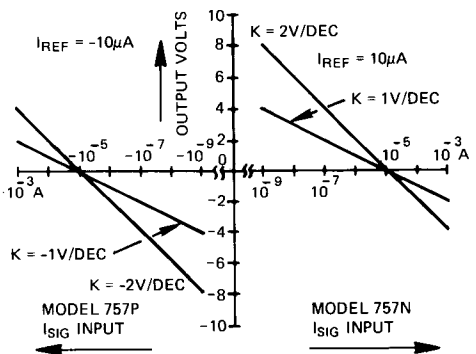

Log mode output voltage vs. input current for  $I_{REF} = 10\mu A$ .

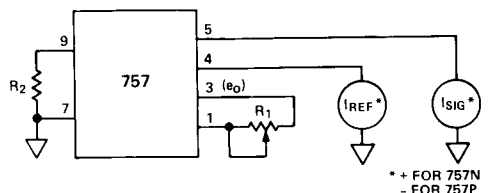

Figure 2. Scale Factor Adjustment

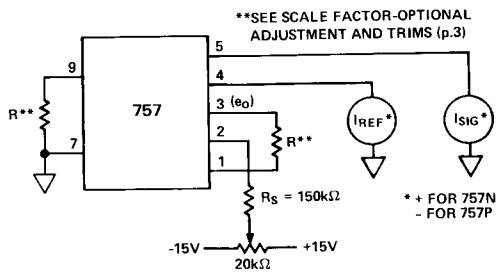

Figure 3. Output Voltage Offset Adjustments

(continued from page 1)

resistor is attached from the voltage signal to the appropriate input current terminal of the 757. Input currents are then determined by:

$$I_{SIG} = \frac{e_1 - e_{os1}}{R_1}, \quad I_{REF} = \frac{e_2 - e_{os2}}{R_2}$$

$e_{os1}$  = Input Offset Voltage ( $I_{SIG}$  Channel)

$e_{os2}$  = Input Offset Voltage ( $I_{REF}$  Channel)

## OPTIONAL ADJUSTMENTS AND TRIMS

**Scale Factor** – A one volt per decade scale factor is available when pin 1 is tied to 3 and pin 7 is connected to 9. Higher scale factors are possible by using a potentiometer,  $R_1$ , between pins 1 and 3 and a resistor,  $R_2$ , between pins 7 to 9 as shown in Figure 2. The value of the required resistor is  $(13.2k\Omega)(K-1)$  where  $K$  is the desired scale factor. The approximate potentiometer value is also  $(13.2k\Omega)(K-1)$ . The scale factor adjustment procedure is as follows:

1. Connect the appropriate value of resistor between pins 7 and 9.
2. Set  $I_{REF} = 1\mu A$ ,  $I_{SIG} = 10\mu A$ . Measure  $e_o$ .
3. Set  $I_{REF} = 1\mu A$ ,  $I_{SIG} = 100\mu A$ . Adjust  $R_1$  until the difference in  $e_o$  corresponding to steps 2 and 3 is  $K$  volts.
4. Repeat steps 2 and 3 until the change in  $e_o = K$  volts.

**Output Voltage Offset** – Output voltage offset must be adjusted after the desired scale factor is established as indicated above. To adjust the offset, inject equal dc input currents into the reference and signal channels. The value of the input currents should approximate the average input current levels expected to be encountered in normal operation. Adjust the potentiometer shown in Figure 3 until the output voltage is zero.

## LOG CONFORMITY

Log conformity in logarithmic devices is a specification similar to linearity in linear devices. Log conformity error is the difference between the theoretical value of the log of a ratio and the actual value that appears at the output of the log-ratio module after scale factor errors have been eliminated. Measurement of this error is made after initially zeroing the module at unity-ratio and adjusting the desired scale factor.

Figure 4 shows the log conformity performance of model 757 over a 6 decade input range. Log conformity for each channel does not vary noticeably as the current is varied in the other channel.

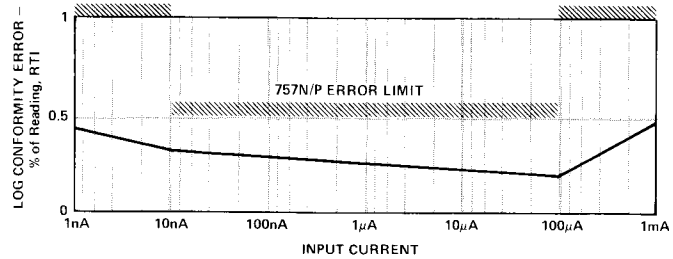

Figure 4. Log Conformity Error for Model 757. Curve is for Either Input Channel with Current Held Constant at  $10\mu A$  On Other Channel.

## FREQUENCY CHARACTERISTICS

Figure 5 shows a plot of small signal response ( $-3dB$ ) as a function of input signal current. The graph demonstrates the frequency response performance for each input channel over the range of  $1nA$  to  $1mA$ , independent of current on the other channel.

As shown in the graph, the reference channel is faster than the signal channel at low input levels. If an application requires higher speed in the input signal channel than in the reference channel, then the channels can be interchanged with a resulting polarity reversal of the output signal

$$\left(\log \frac{I_{SIG}}{I_{REF}} = \log I_{SIG} - \log I_{REF} = -\log \frac{I_{REF}}{I_{SIG}}\right).$$

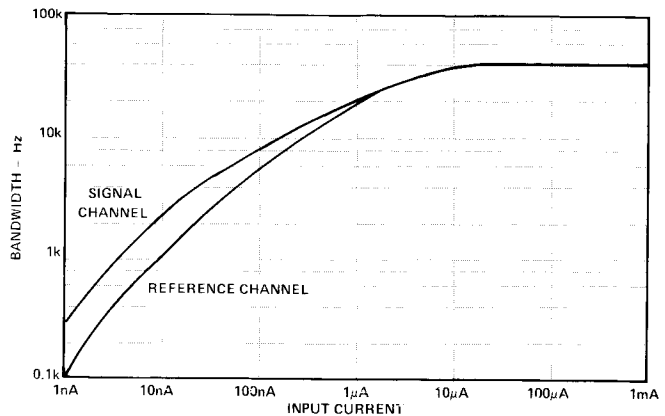

Figure 5. Small Signal Bandwidth ( $-3dB$ ) vs. Input Signal Level

## APPLICATIONS

**Data Compression** – Processing signals with wide dynamic range is a common problem in instrumentation and data transmission. For example, digitizing an analog signal with a range of 10nA to 100μA with 1% accuracy requires a 20 bit A/D converter. (Required resolution =  $1/100 \times 1/10,000 = 1/10^6 \cong 1/2^{20}$ ).

By using the 757 with  $I_{REF}$  adjusted to 10nA and K set for 5/4 V/decade, the input data can be compressed into a 5 volt output range. For a 1% resolution of any signal, the allowable output error is  $4.32\text{mV} \times K$ . Log conformity contributes  $2.17\text{mV} \times K$  (0.5%) over this range. The remaining error with  $K = 5/4$  is  $2.69\text{mV}$  and should correspond to less than the LSB of the converter. With a 5 volt output range  $2.69\text{mV}$  corresponds just over the LSB of an 11-bit converter. Thus the 757 module can compress the data for use with a 12 bit A/D (such as Analog Devices AD574JD) to obtain the desired 1% resolution.

**Absorbance Measurements** – Critical properties of materials which are of particular interest in the fields of chemistry, medicine, spectrometry and pollution control are characterized by absorbance. The relationship between absorbance, A, and light intensity, I, is:  $A = \log I_0/I_T$  where  $I_0$  = intensity of incident light, and  $I_T$  = intensity of transmitted light.

Figure 6 shows the 757 log-ratio module used in such a photometer application. Two inputs represent the intensities of light transmitted through space and through a medium that absorbs light. The absorbance of the medium is given by the formula

$$A = \log \frac{I_{\text{SIGNAL}}}{I_{\text{REFERENCE}}}$$

where  $I_{\text{SIGNAL}}$  and  $I_{\text{REFERENCE}}$  are the currents representing the light intensities.

The transducers used in this application are photodiodes, which provide a short-circuit current proportional to the intensity of applied light. The lowest value of absorbance is determined by the value of  $I_{REF}$ , since when  $I_{SIG} = I_{REF}$ ,  $A = 0$ . The output of the log-ratio module is externally trimmed to 1V/decade and applied to the input of a 3½-digit DPM through the scaling network R1 and R2.

Model 757 was chosen for this design because it makes available both amplifier summing junctions. When the photodiodes are connected to the summing junctions, they are operated in the short-circuit mode, that is, with zero volts across the diodes.

Short-circuit loading is necessary, because accuracy of the photodiodes can be degraded several percent when operated with as little as 100mV across the diode junction.

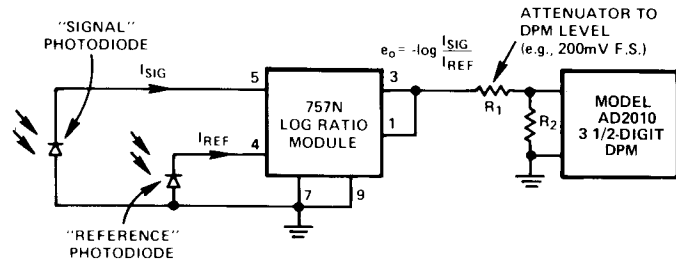

Figure 6. Model 757N Applied to Absorbance Measurements

## INTERCONNECTION GUIDELINES

Model 757 is a complete log ratio amplifier that requires no additional frequency compensation for proper operation.

**Input Capacitance** – Model 757 is able to operate with 1000pF at both input terminals. Therefore, the 757 can be used in applications requiring long cable lengths between the module and the signal transducers.

**Input-to-Output Capacitance** – When using a log ratio module the user should take care in system configurations to avoid excessive stray capacitance between input and output terminals. Such precautions include avoiding running input and output signal lines close together. If long cable runs are required where inputs and output are closely bundled together, it is advisable to enclose the inputs and/or output in separate, grounded electrostatic shields. By observing simple rules of good circuit layout, problems with oscillations that may result from excessive input-to-output capacitance can easily be avoided. Model 757 can accommodate up to 100pF of input-to-output capacitance without oscillation.

**Leakage Resistance** – Since model 757 can operate at extremely low input current levels, precautions must be taken to prevent current leakage into the input terminals. Such leakage can cause errors when small input or reference currents are used. This problem may arise on printed circuit layouts if the inputs are run too close to the power supply busses. Providing an etched guard around the input lines, connected to analog signal ground will also reduce unwanted current leakage.